

Trim Panel, Center Console, Lower, LH (Remove and Replace)

Labor Code: 643726010

Important:

This manual is written for professional automotive technicians who have received high voltage training. It is the technician's responsibility to make sure that the vehicle is safe to work on before beginning inspections or repairs, and to perform all work in a safe manner and in a safe work environment. Refer to the [Introduction](#) section for additional important information.

Potentially Non-Reusable Component(s):

| Part Number | Quantity | Fastener Type |
|--------------|----------|--------------------------|
| SC00007427-A | 4 | Adhesive |

Torque Specifications:

| Step Number | Torque (Nm) |
|--------------------|-------------|
| 4 | 1.5 |
| 7 | 93 |
| 10 | 93 |

Removal

1. Remove: [Trim Panel, Center Console, Lower, Rear \(Remove and Replace\)](#).
2. Remove: [Cover, Center Console, HVAC \(Remove and Replace\)](#).
3. Remove: [Cover, Instrument Panel, Bottom, Center, LH \(Remove and Replace\)](#).
4. If equipped:

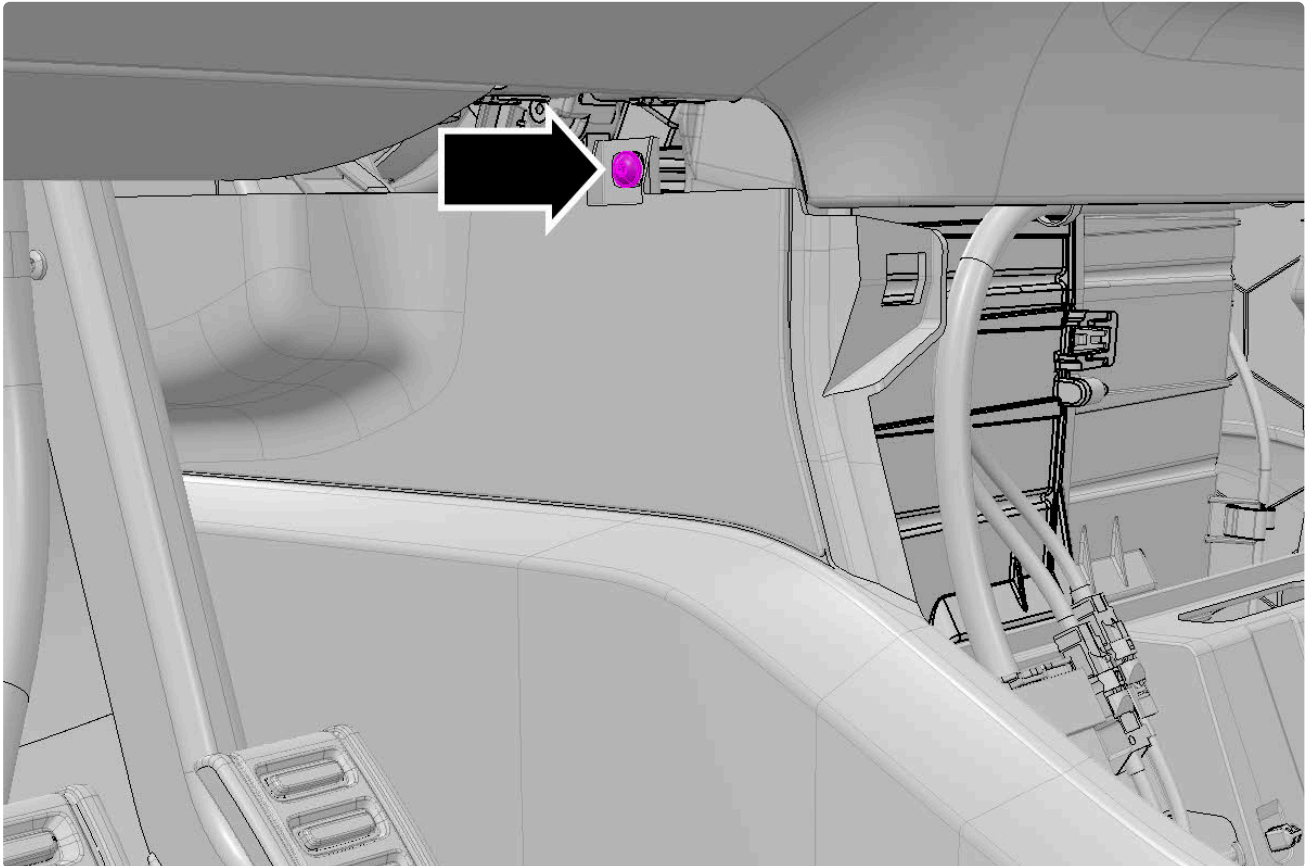

Torque: 1.5 Nm

5.

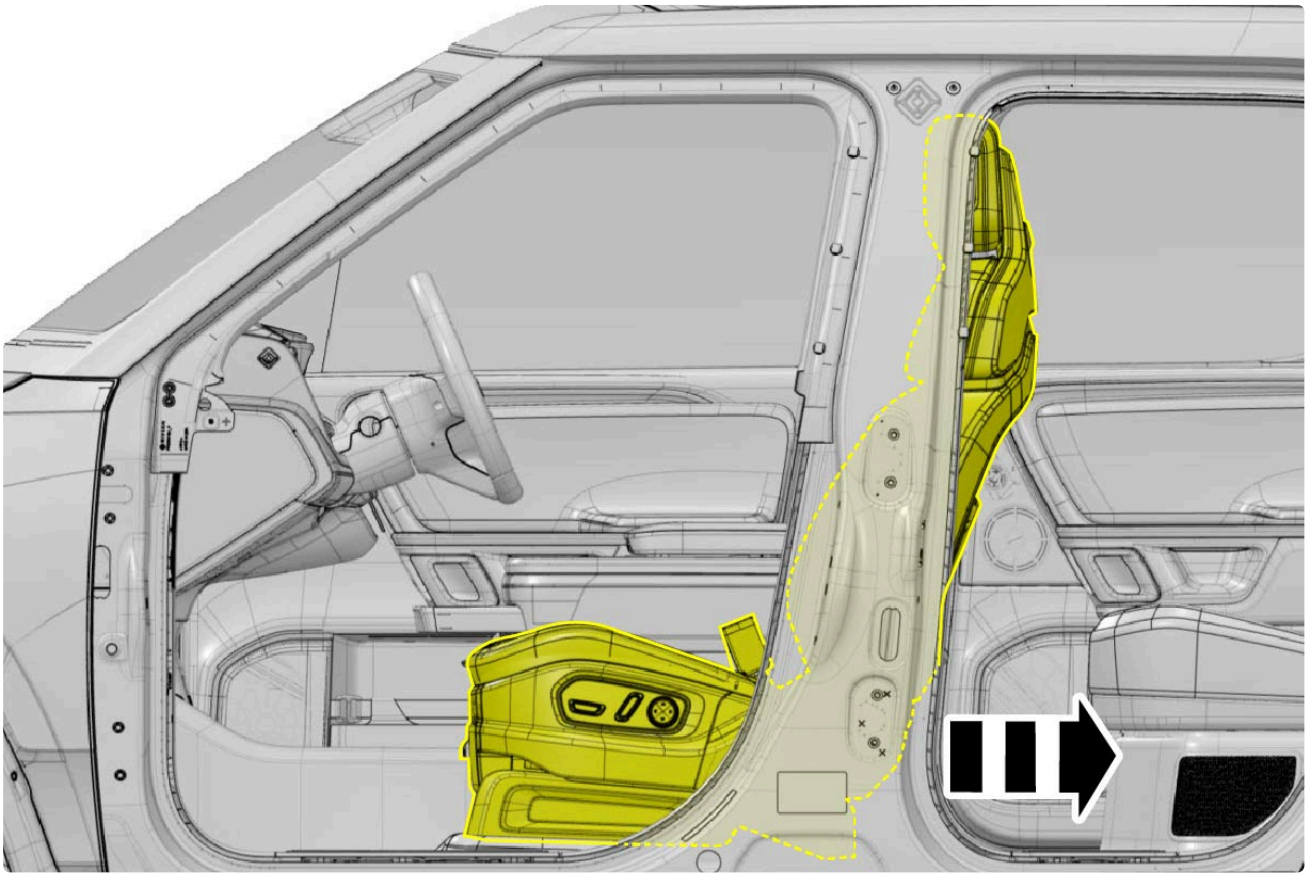

6. Using a trim tool:

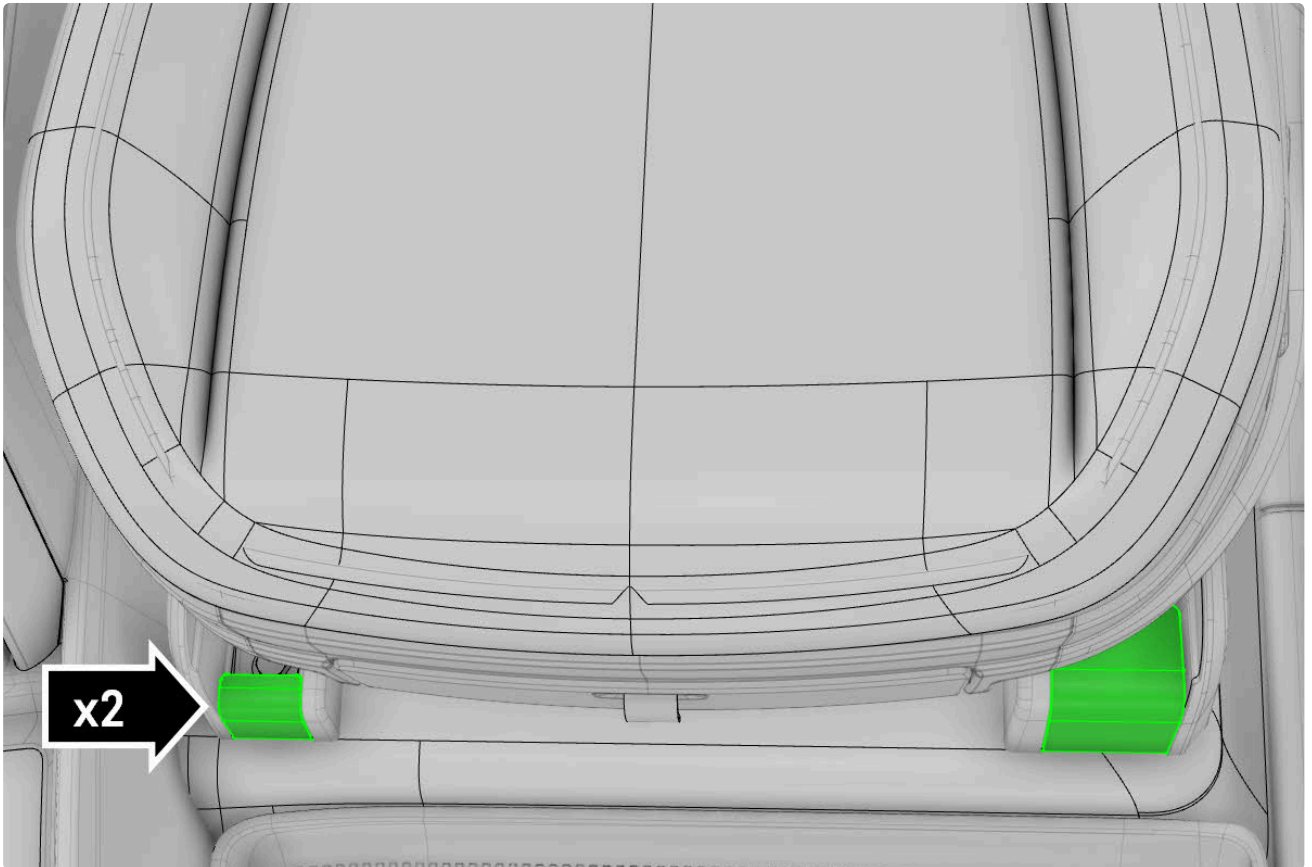

7.

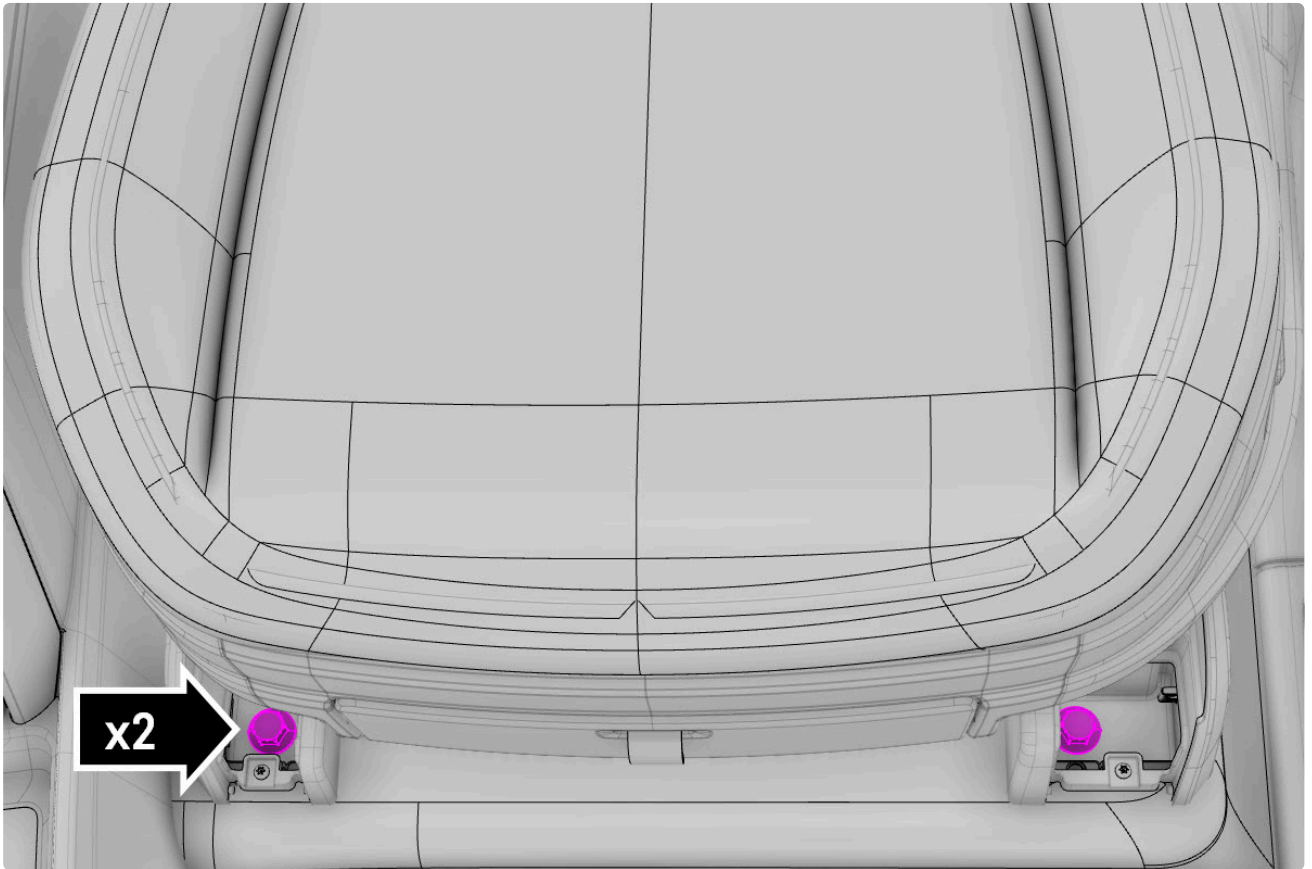

CAUTION:
Potentially non-reusable fastener(s).

Torque: 93 Nm

8.

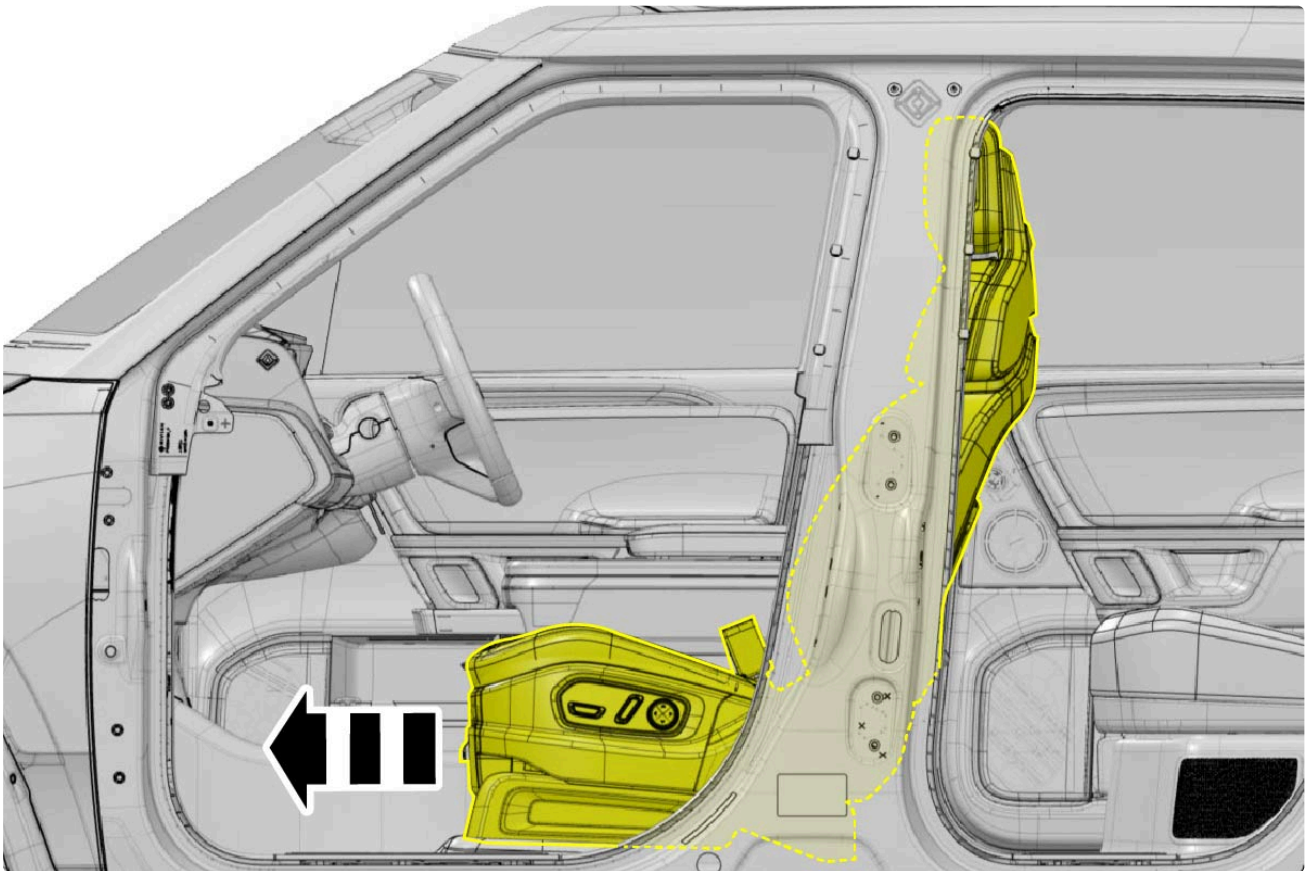

9. Using a trim tool:

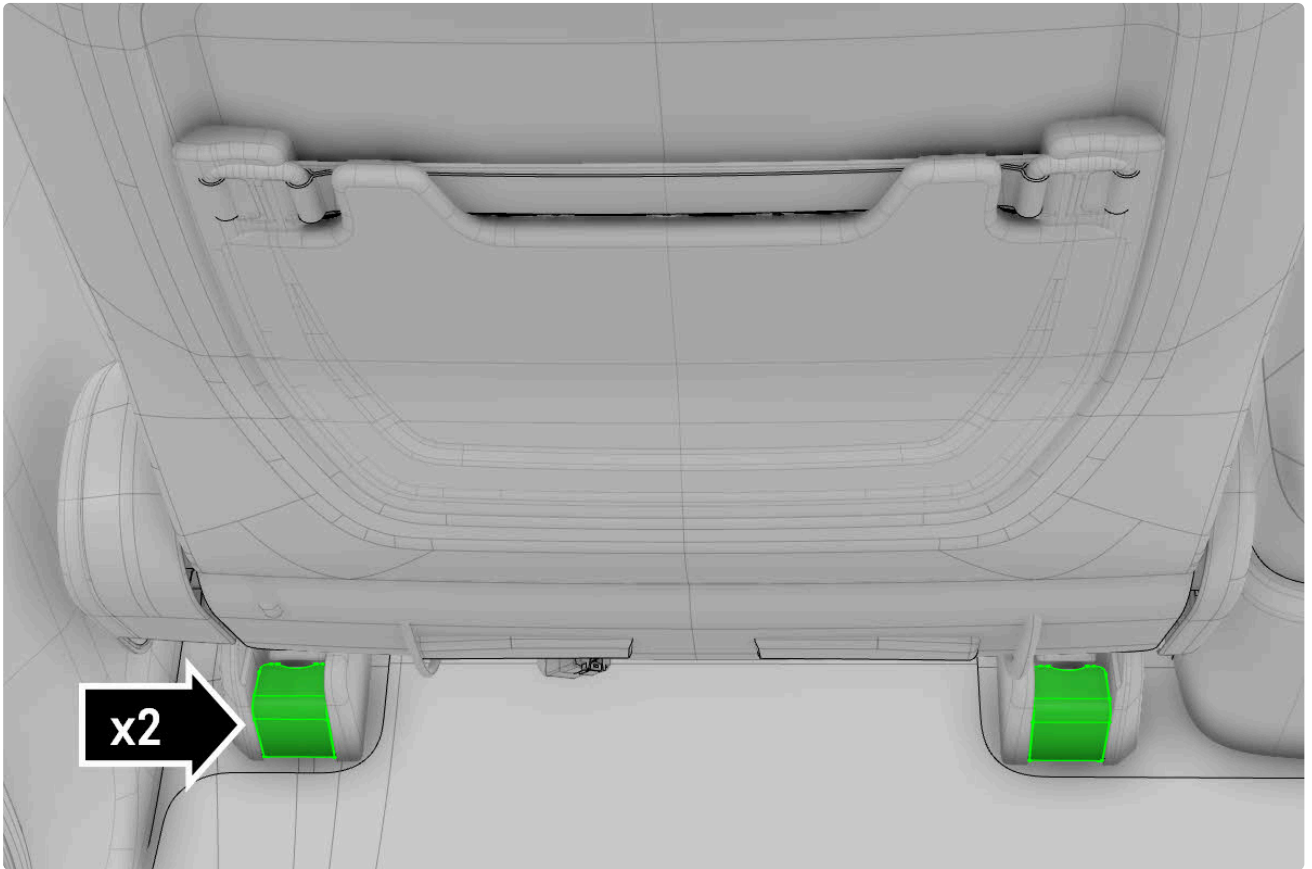

10.

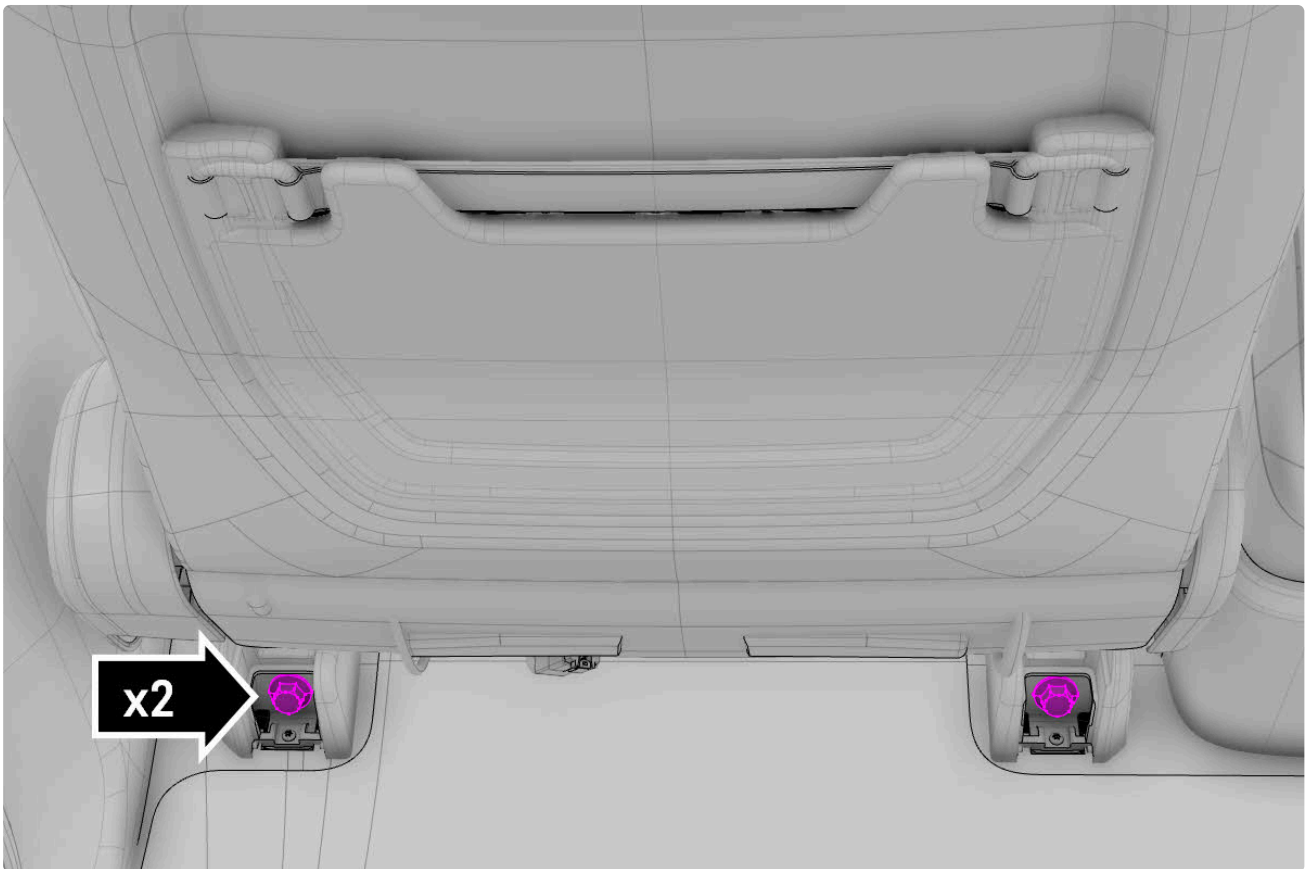

CAUTION:
Potentially non-reusable fastener(s).

Torque: 93 Nm

11. Cover the highlighted component(s) with protective material to prevent damage.

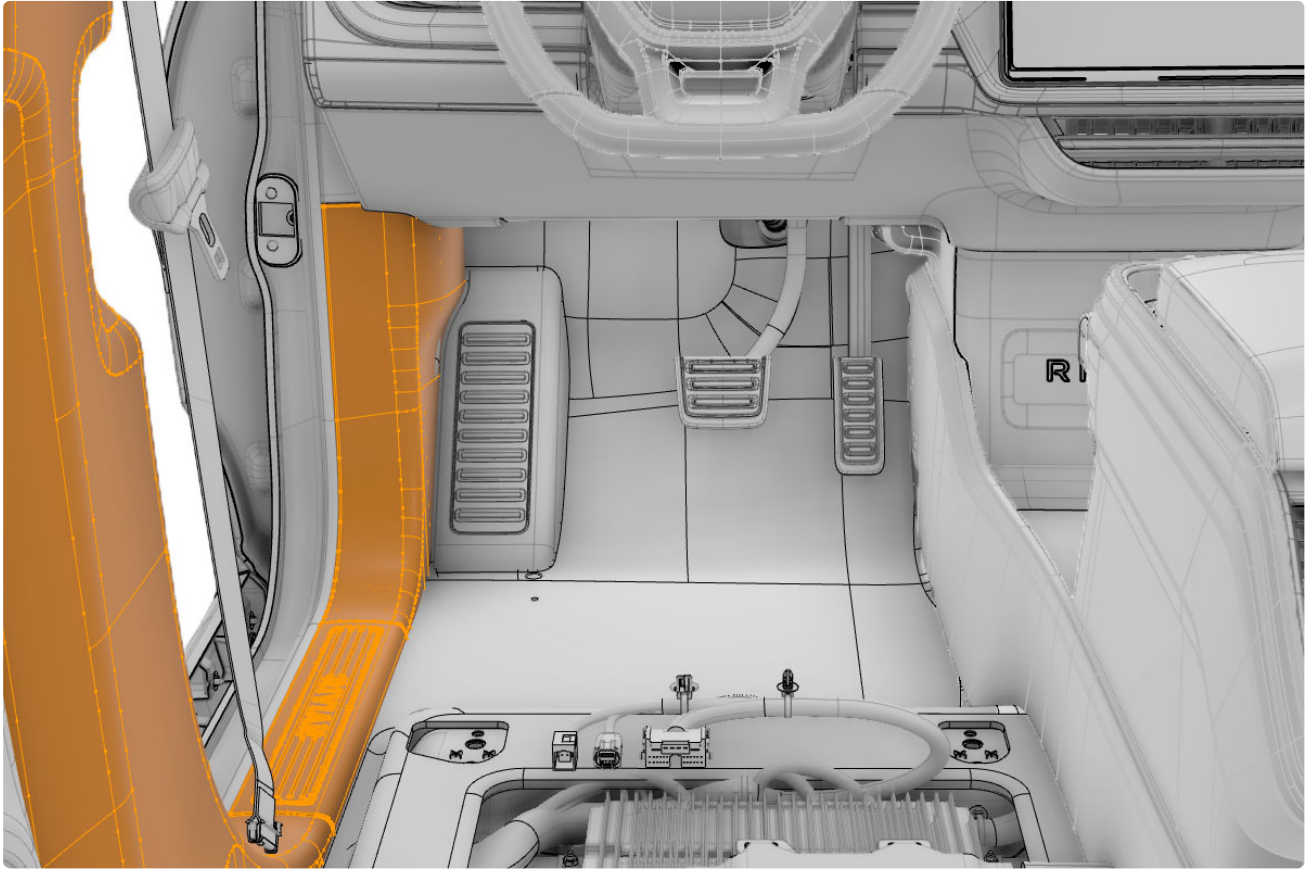

Note:

Shown with components removed for clarity.

12.

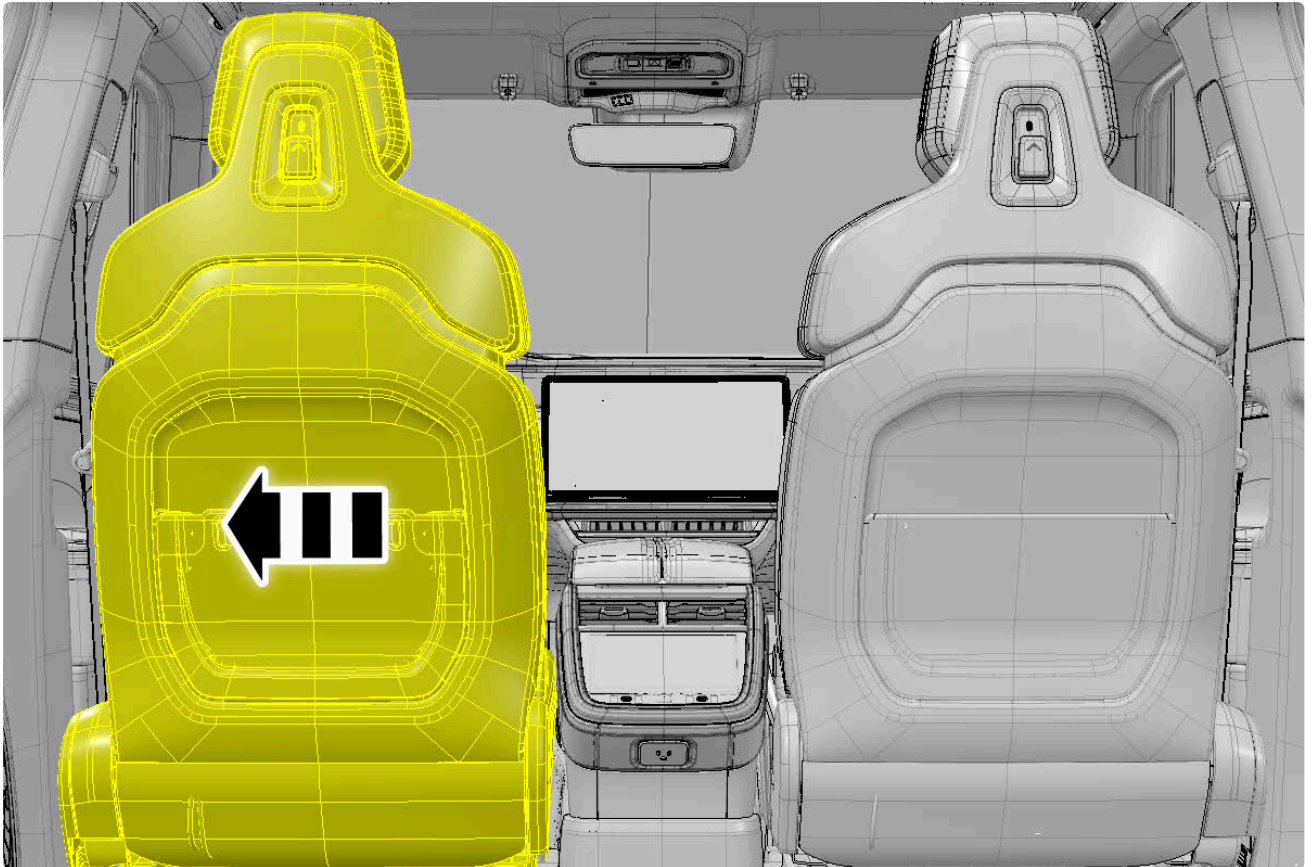

13. Use a trim tool to pry near the highlighted clip(s).

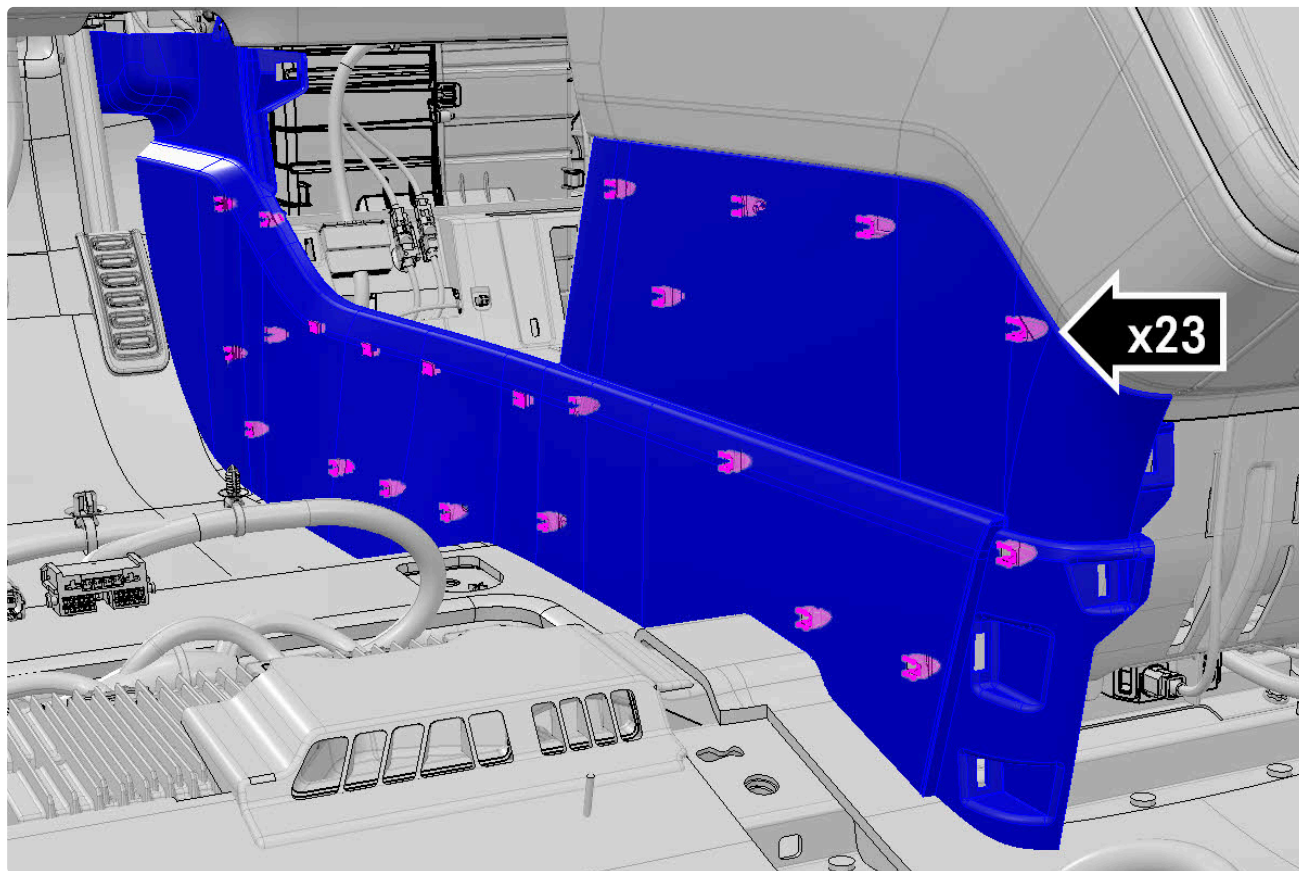

Note:

The number of clips varies depending on the build date of the vehicle.

Installation

Installation is the reverse of removal, except for the following:

- If the same component will be re-installed: Check the towers that support the U-shaped metal clips. Bent or misaligned clip towers can be bent into the proper position if they are not cracked or torn. If a clip tower is cracked or torn, replace the component.
- If the same component will be re-installed: Replace any damaged clips.

Install the component(s) in the order shown.

1.

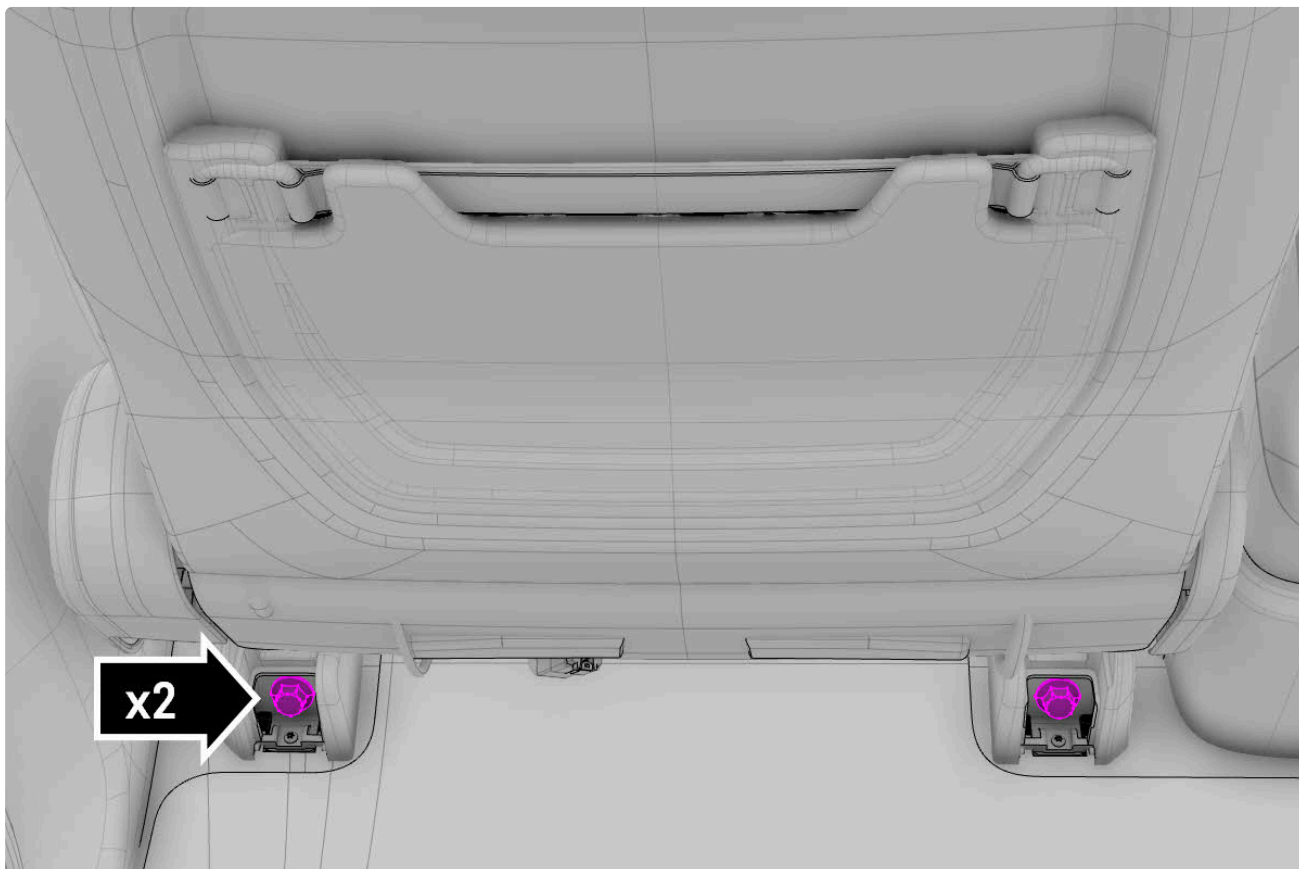

CAUTION:
Potentially non-reusable fastener(s).

2.

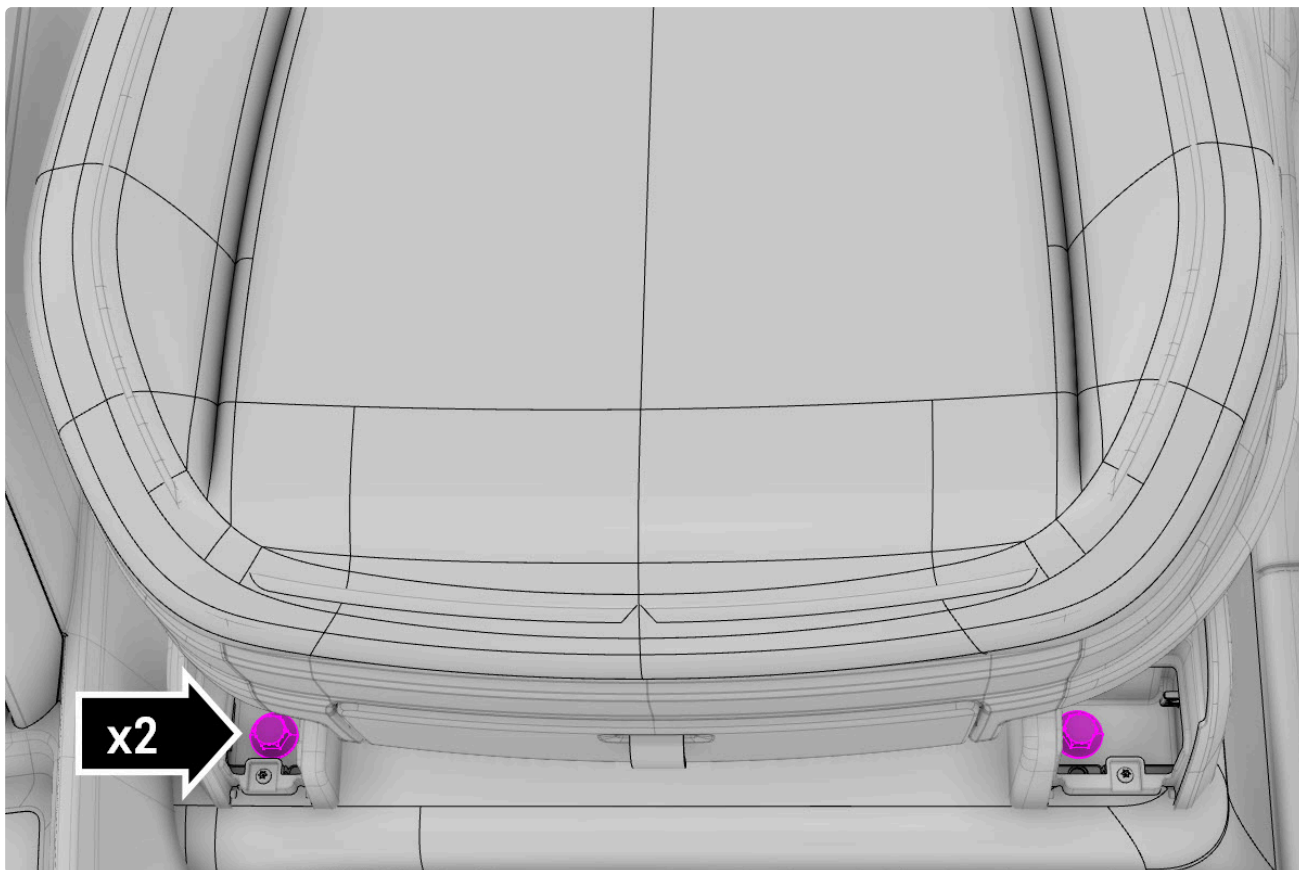

CAUTION:
Potentially non-reusable fastener(s).

3. Reinstall the remaining component(s).