

Trim Panel, Quarter Panel, LH (Remove and Reinstall)

Labor Code: 648270011

Important:

This manual is written for professional automotive technicians who have received high voltage training. It is the technician's responsibility to make sure that the vehicle is safe to work on before beginning inspections or repairs, and to perform all work in a safe manner and in a safe work environment. Refer to the [Introduction](#) section for additional important information.

Removal

1.

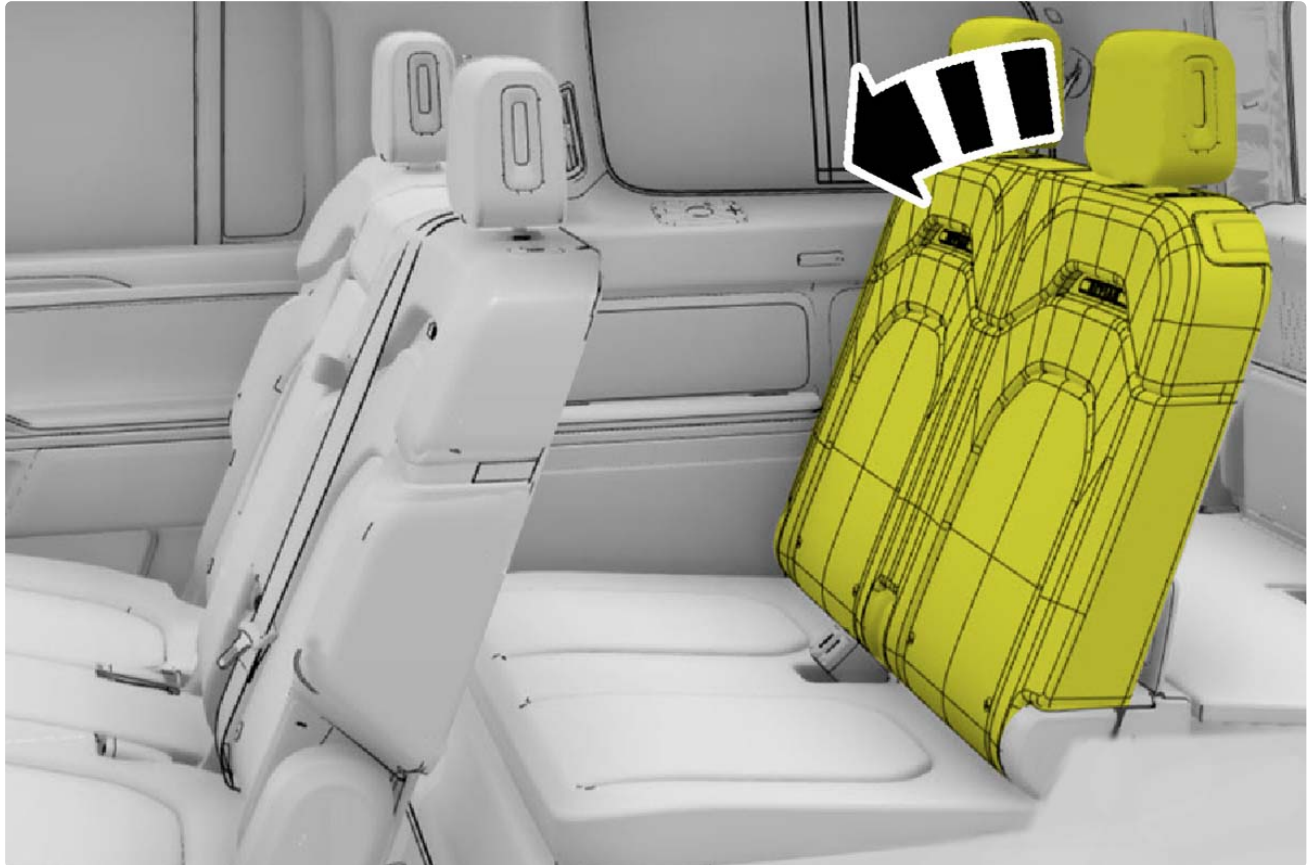

2.



3. Remove: [Trim Panel, C-Pillar, Lower, LH](#) (Remove and Replace).

4.

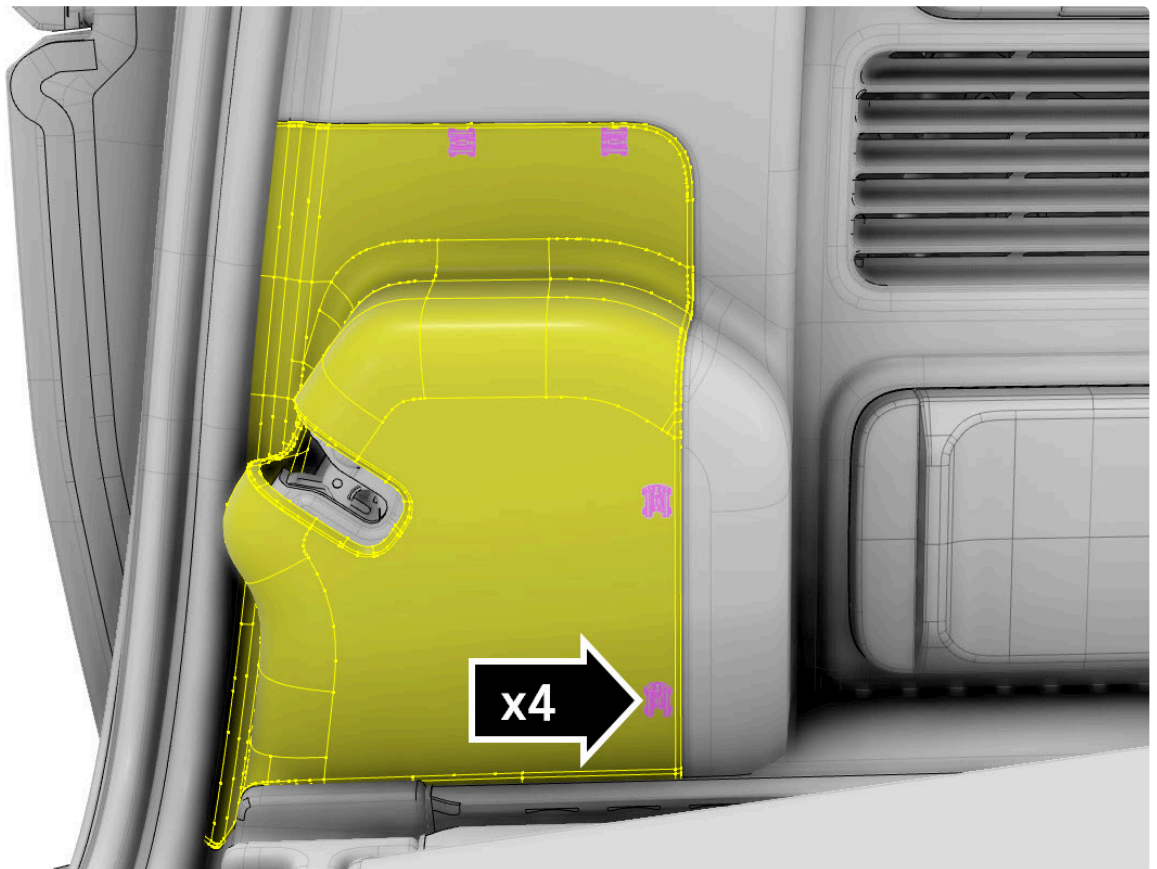

5. Use a trim tool to pry near the highlighted clip(s). Do not fully remove the component at this time.

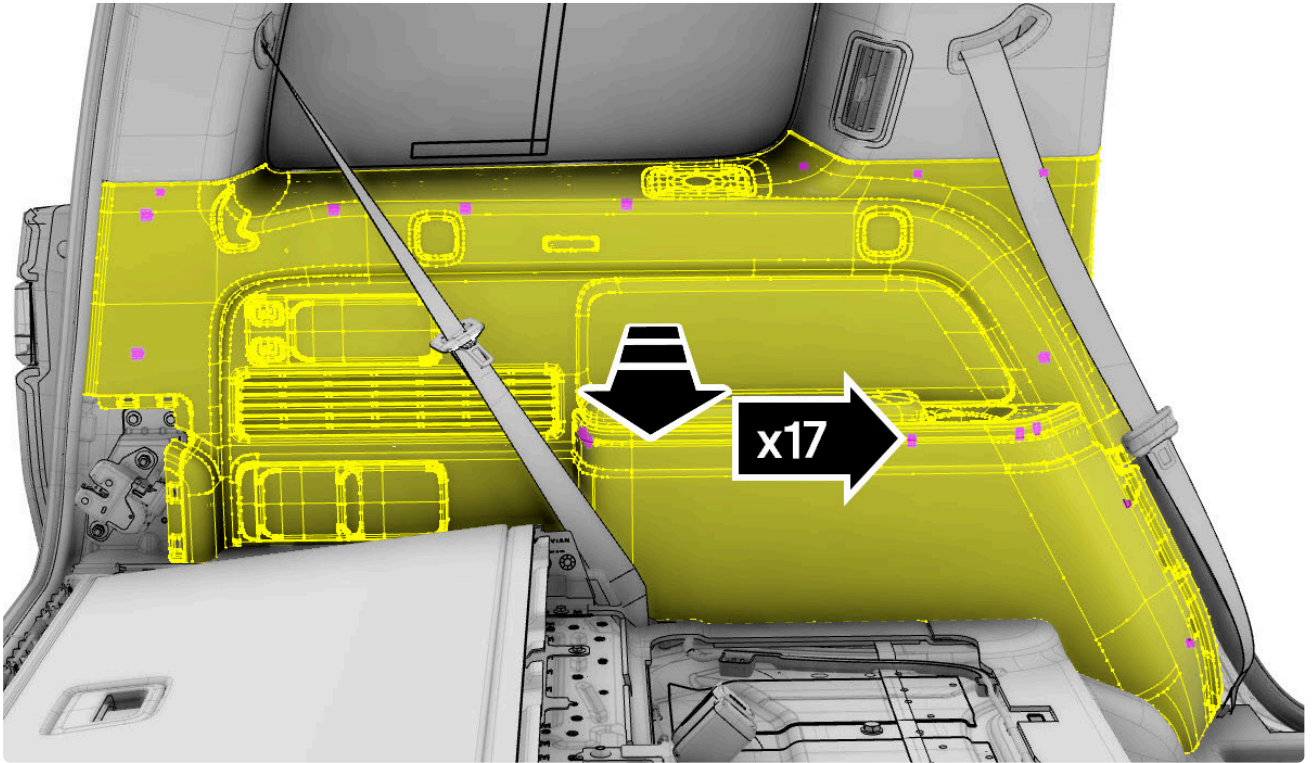

Note:

Shown with components removed for clarity.

6. One of the following:

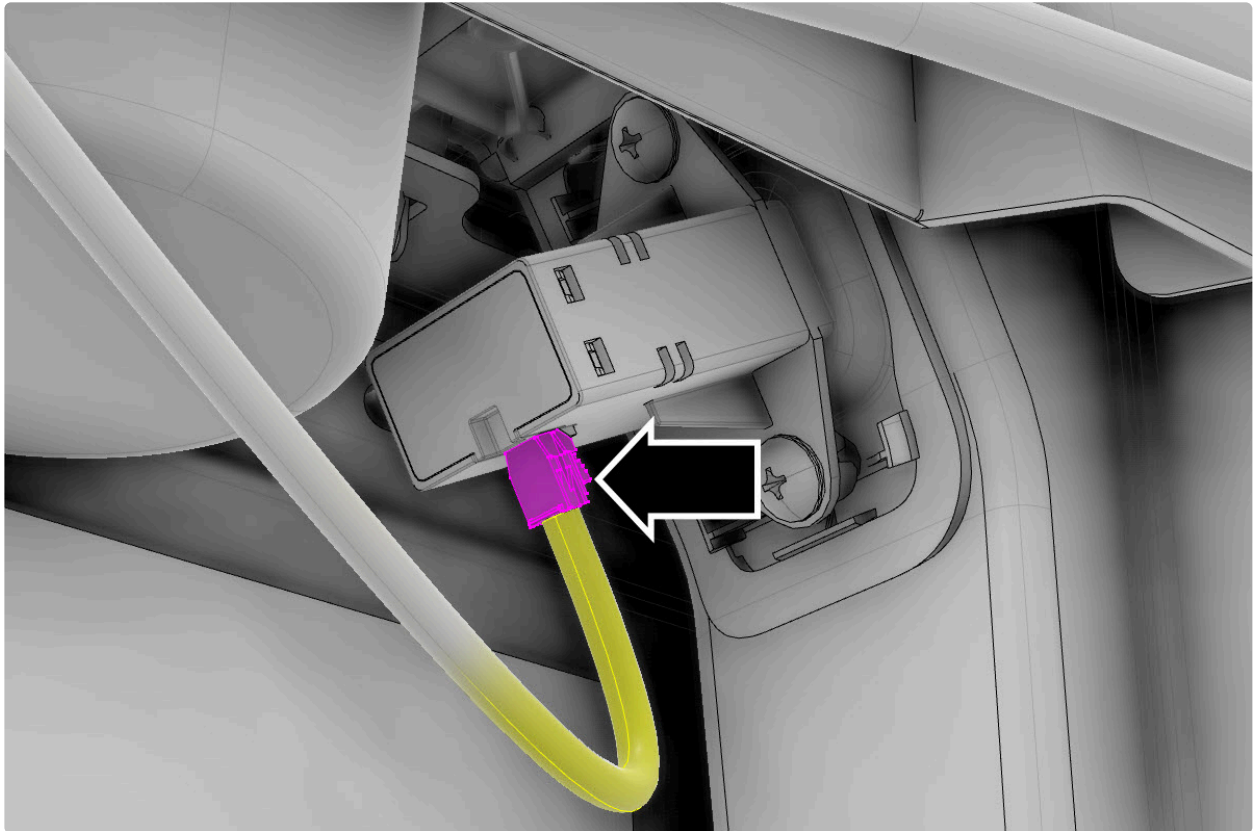

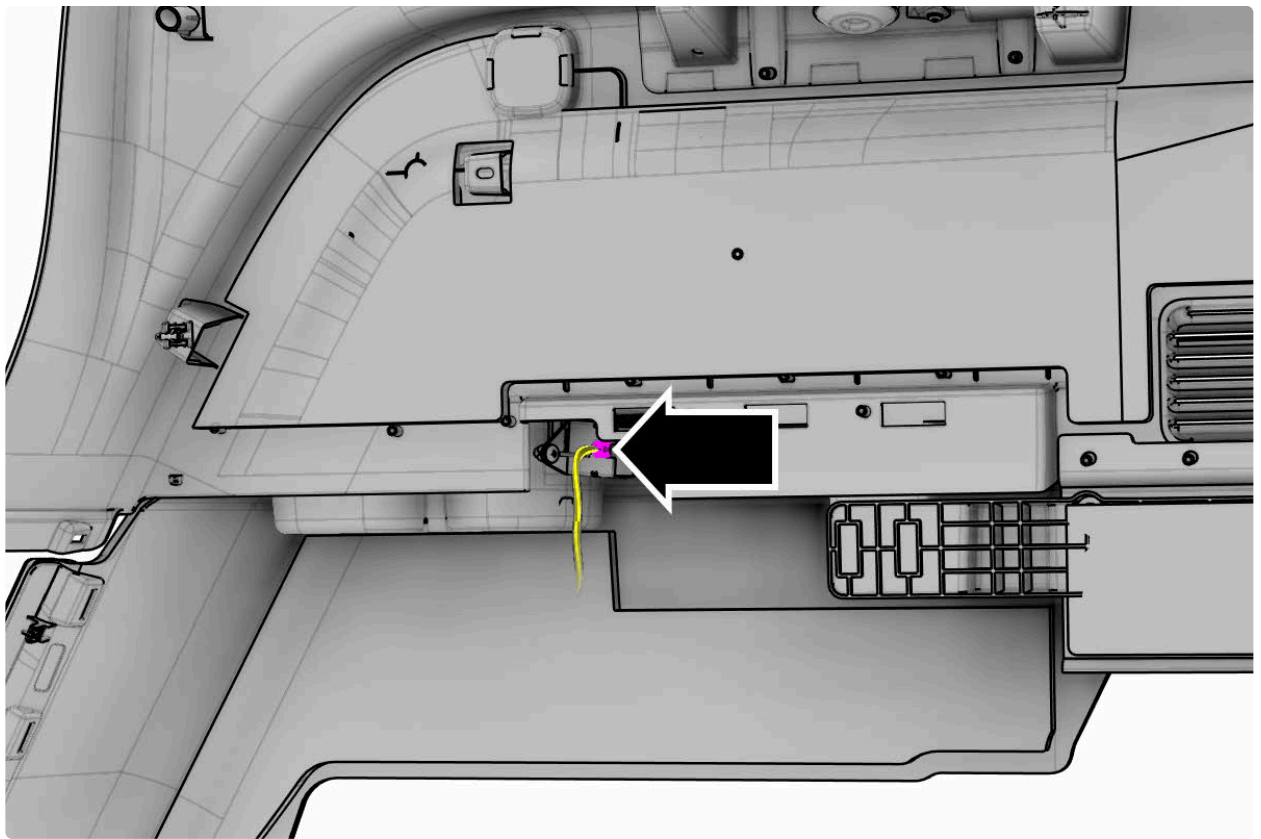

7.

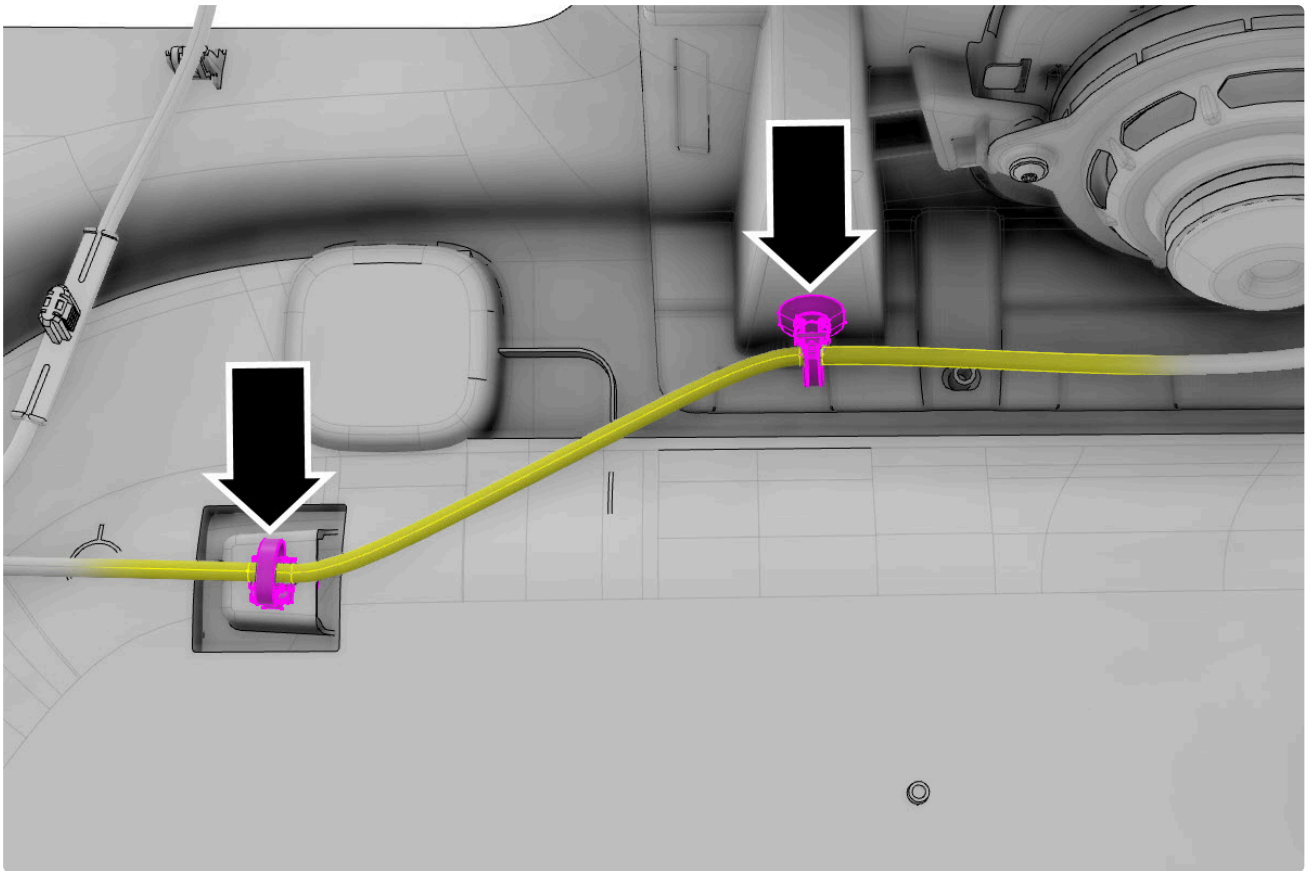

8.

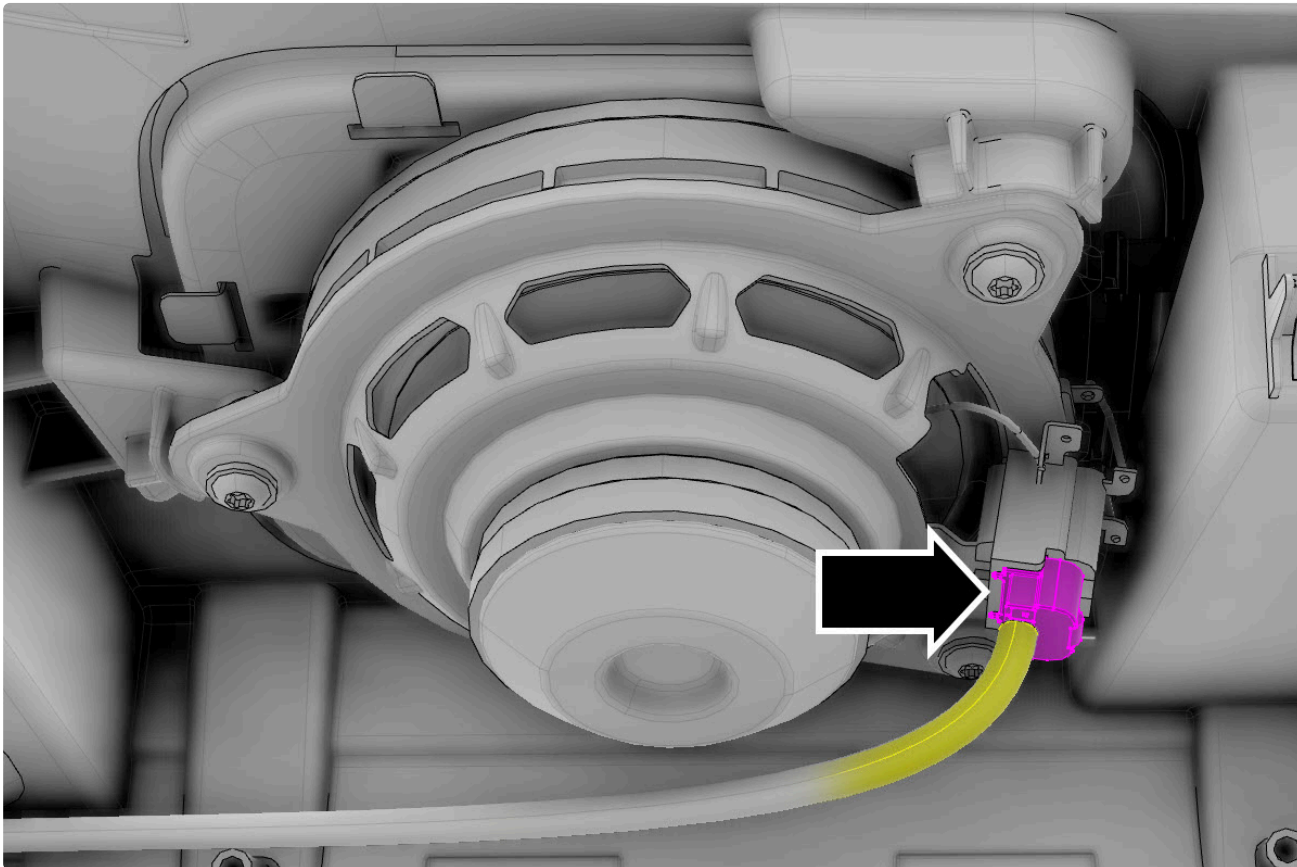

9.

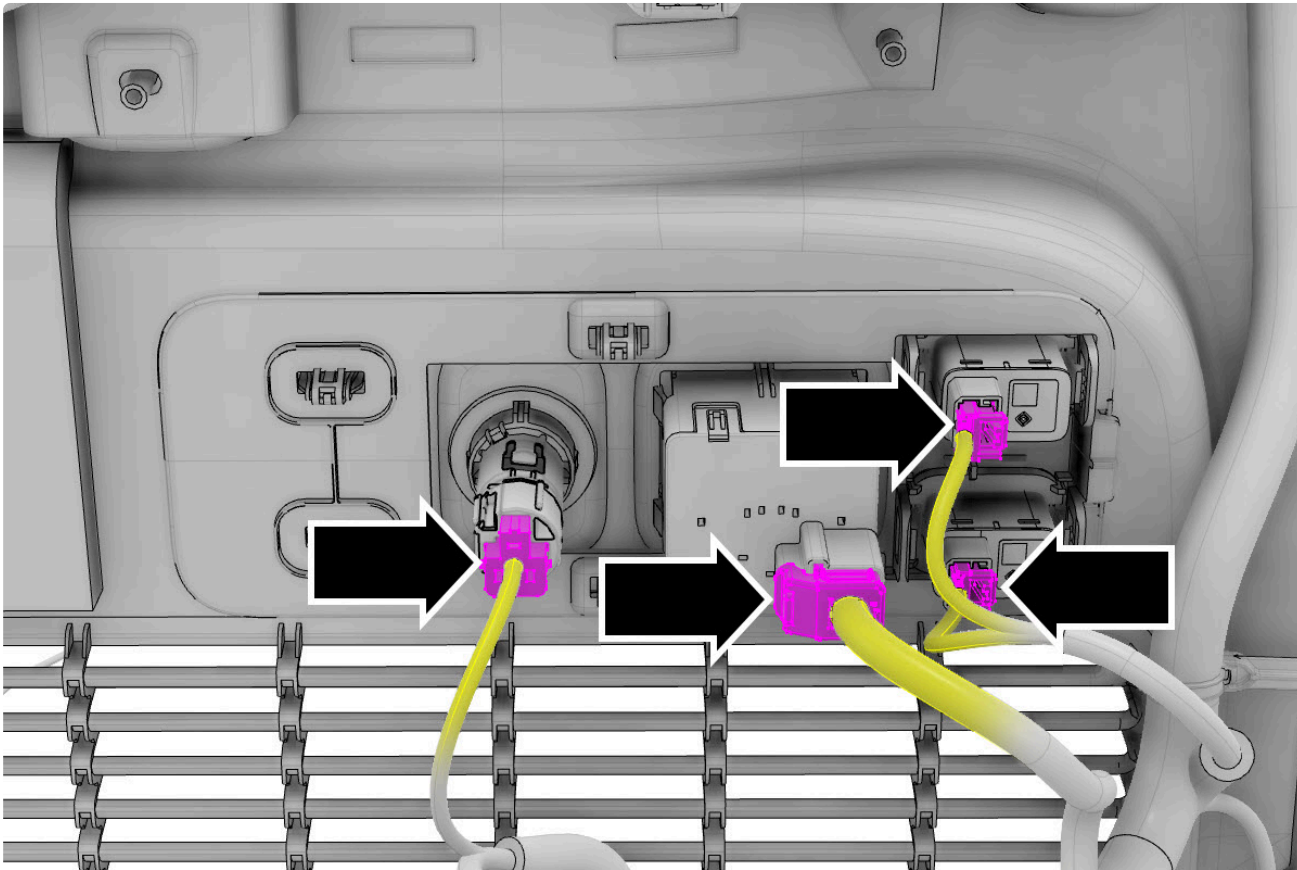

10.

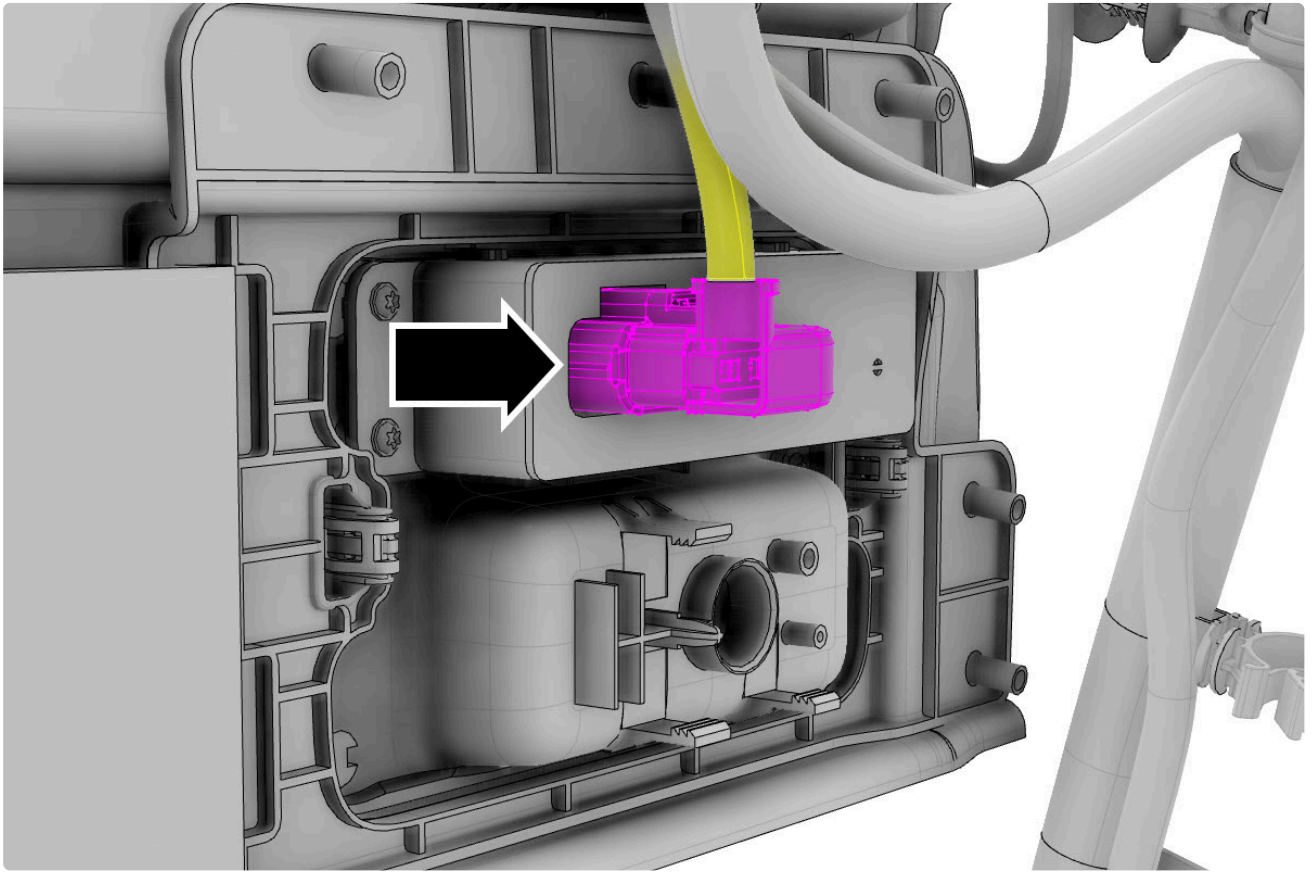

11. Vehicles built after approximately January 24, 2023:

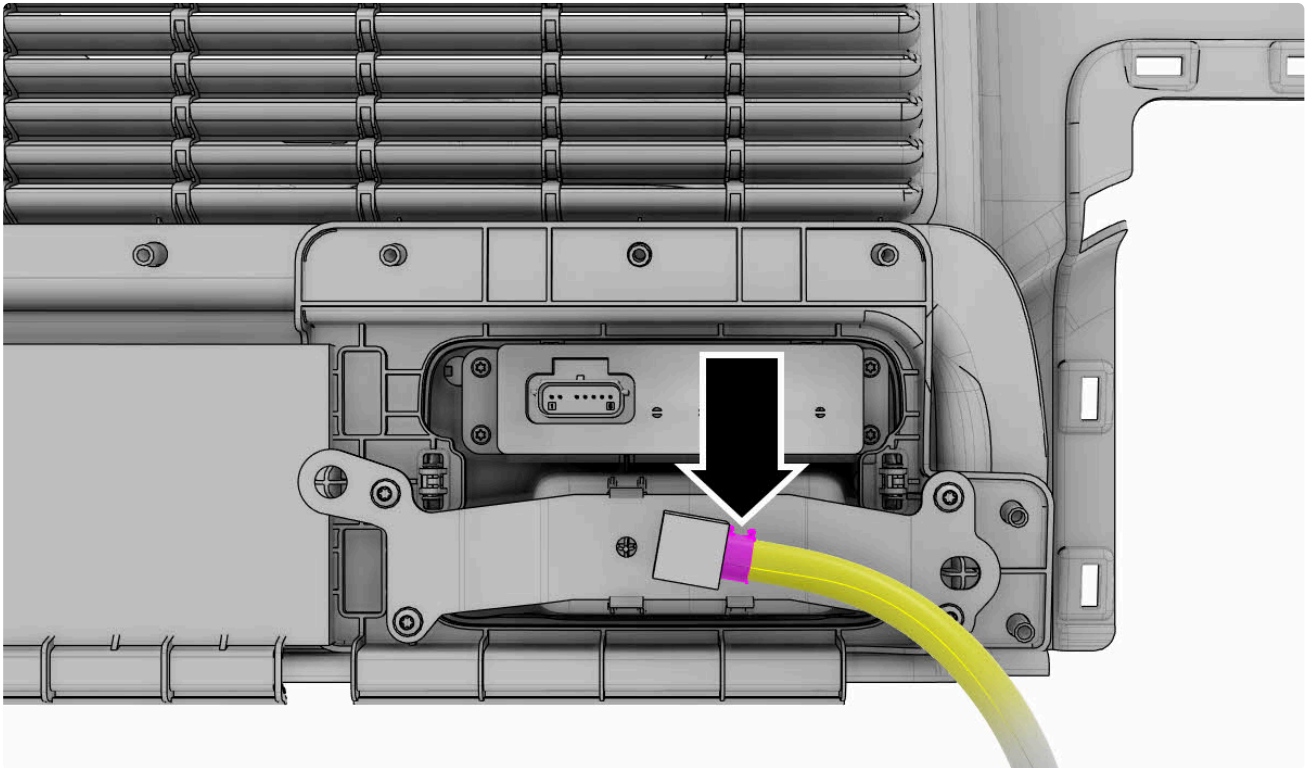

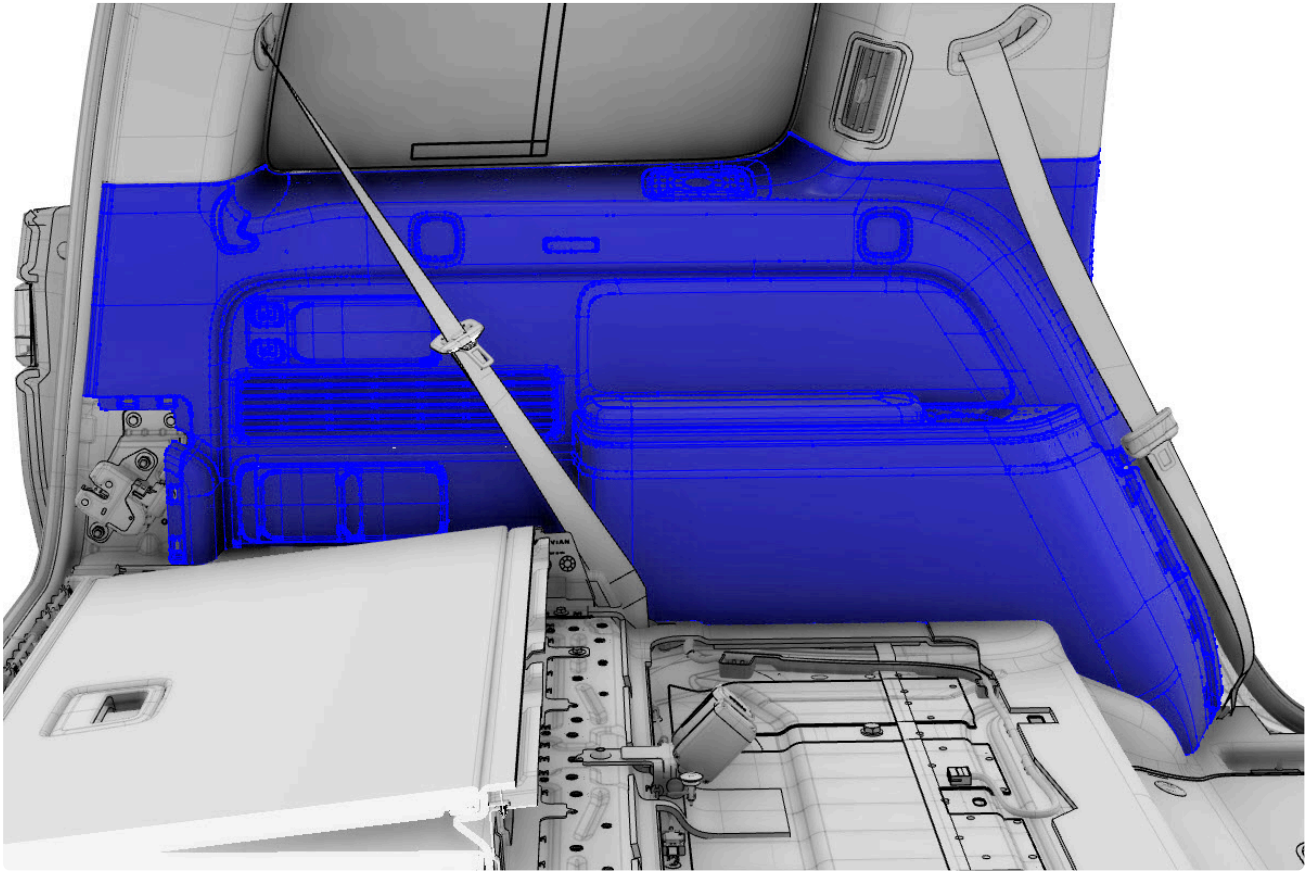
**Note:**

Shown with components removed for clarity.

Installation

Installation is the reverse of removal, except for the following:

- If the same component will be re-installed: Check the towers that support the U-shaped metal clips. Bent or misaligned clip towers can be bent into the proper position if they are not cracked or torn. If a clip tower is cracked or torn, replace the component.
- Vehicles built before approximately January 24, 2023: Using non-marring pliers:

